

# PACKAGED BOILER FEEDWATER SYSTEM

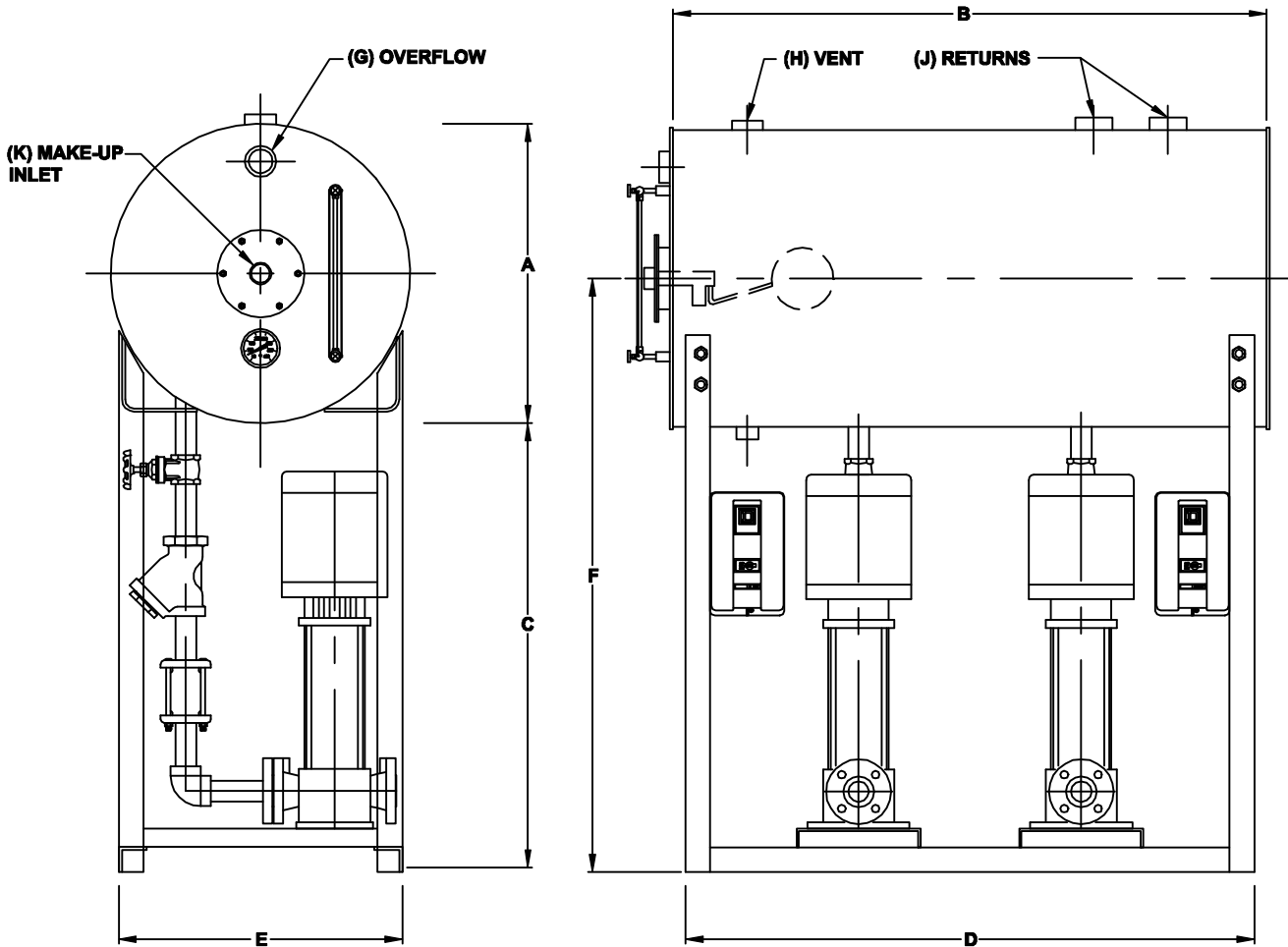

CAPACITY IN GALLONS	RECEIVER		STAND			MAKE-UP CENTERLINE F	OVERFLOW OUTLET G	VENT OUTLET H	RETURN INLET J
	O.D.	LENGTH	HEIGHT	LENGTH	WIDTH				
	A	B	C	D	E				
100	24	48	DIM. VARIES PER BOILER HP & OPER. PRESS.	46	22-3/4	ADD 1/2 O.D. TO STAND HEIGHT	1-1/2	1-1/2	2
220	30	72		70	27-1/2		2	2	3
330	36	72		70	32		3	3	3
500	48	60		56	40		3	4	3
750	48	96		92	40		3	4	3
1000	48	120		108	40		3	4	3

**NOTES:**

1. ALL DIMENSIONS IN INCHES UNLESS OTHERWISE NOTED.
2. Y-STRAINERS SHOWN ARE OPTIONAL.
3. STAND HEIGHT IS DETERMINED BY ACTUAL BOILER HP. & OPERATING PRESSURE.
4. MAKE-UP INLET (K) IS DETERMINED BY SYSTEM CAPACITY.
5. ONE, TWO, or THREE BOILERFEED PUMPS CAN BE ACCOMODATED INTO STAND.

**ATLANTIC FEEDWATER SYSTEMS, INC.**

1403 SW 7th. STREET, ATLANTIC, IOWA 50022

DATE: 09/06/00

DRAWN BY: RG

APPROVED:

DWG No.: FS GA

REV No.: